

envision

pixie

THIS MICRO CHLORINE GENERATOR
CREATES A TOTALLY REJUVENATING
SPA AND PLUNGE POOL EXPERIENCE.



Universal Model

This manual is for:
PIXIE RP10 MODELS

ERP10H (Euro model)
RP10TH (Universal model
with timer)
RP10QTH (With battery
backup)

INSTRUCTION MANUAL

DISCLAIMER

- While every effort has been made to ensure that the information contained in this guide is accurate and complete, no liability can be accepted for any errors or omissions.
- Australian Innovative Systems Pty Ltd (AIS Water) reserves the right to change the specifications of the hardware and software described herein at any time without prior notice.
- No part of this guide may be reproduced, transmitted, transcribed, stored in a retrieval system, or translated into any language in any form, by any means, without the prior written permission of Australian Innovative Systems Pty Ltd.
- Australian Innovative Systems makes no warranties for damages resulting from lack of supply of chlorine due to a mistaken operation or malfunction of the chlorine generator or use of non-genuine replacement parts.

TRADEMARK ACKNOWLEDGEMENTS

Pixie™ is a trademark of Australian Innovative Systems Pty Ltd.

USE OF GENUINE AUSTRALIAN INNOVATIVE SYSTEMS REPLACEMENT PARTS IS RECOMMENDED.

This product is designed to perform optimally when used with genuine Australian Innovative Systems replacement parts. Australian Innovative Systems Pty Ltd shall not be liable for any damages to this product caused by the use of non-genuine replacement parts (e.g. electrode). Please note that this warranty does not apply to repairs arising out of the malfunction of non-genuine replacement parts, although you may request such repairs on a chargeable basis.

PURCHASED FROM: _____

PURCHASED DATE: _____

NOTE: Proof of purchase / installation is required for warranty claims. Please keep your records in a safe place.

CHLORINE GENERATOR FUNCTIONS



1. Status Light 1 – High Salt

If the light is on see Troubleshooting guide, page 17.

2. Status Light 2 – Cell Off / Salt Low

If the light is on or flashing see Troubleshooting guide, page 17.

3. Status Light 3 – Power On / No Water Flow

If light is steady, unit is powered. If the light is flashing, see Troubleshooting guide, page 17.

4. Status Light 4 – Overload / Normal Operation

When light is ON/Steady and machine is beeping, the chlorine generator power supply is on standby due to failure. Contact manufacturer for service.

When flashing, machine is working in reverse cycle (normal operation).

5. Chlorine Controller

Turn clockwise to increase the chlorine output and anti-clockwise to reduce the chlorine output.

(Note: When chlorine output lights are off and 'power on (light 3)' and 'cell off (light 2)' lights are on, chlorine production is in standby mode).

6. Chlorine Output Indicators

Each light on represents 10% of chlorine output (e.g. 5 lights on = 50% output).

7. Time Clock (Timer models (RP10TH and RP10QTH) only)

See page 12 for operation.

8. Circuit Breaker

If tripped, refer to Troubleshooting guide on page 17.

9. Time Clock Bypass (Timer models (RP10TH and RP10QTH) only)

See page 13 for operation.

10. Pump Outlet Socket

The three-pin plug supplying power to the pump is connected here.

THE PIXIE™ SALTWATER CHLORINATION SYSTEM

Congratulations on your choice of a Pixie™ saltwater chlorinator system for your swimming pool. The Pixie™ saltwater chlorinator you have purchased is designed for easy and simplistic operation and maintenance. By following these instructions, you are assured years of trouble-free operation.

These instructions have been compiled and produced to help you get the maximum results from your unit and to assist you to fully understand and correctly operate your Pixie™ saltwater chlorinator.

Please take the time to read these instructions thoroughly before attempting to operate your unit. Should you require additional information or further assistance, please do not hesitate to contact your local Pixie™ representative or visit our website www.aiswater.com.au.

WATER BALANCE

For best performance and operation of your Pixie™ saltwater chlorination system, certain water balances must be maintained within your swimming pool. Please check your pool water and ensure that your chemical balances are within the following guidelines.

Chlorine	2.0 – 4.0 ppm
pH	7.2 – 7.8
TA (Total Alkalinity)	80 – 200 ppm
Hardness	150 – 350 ppm
Cyanuric acid	30 – 50 ppm
Phosphates	0 – 500 ppb
Salinity	4,000 – 5,500 ppm

Adjust your pool water balance to achieve the above levels. Your local pool shop can assist here to give you accurate readings and aid in correct dosages as necessary.

CHLORINE GENERATOR INSTALLATION

FITTING THE CHLORINATOR CELL HOUSING

The Pixie™ cell housing must be plumbed into the return line of the pool filter system after the filter and any diversion valves. Please refer to the installation diagram for the correct method of installation (Fig. 3) and note installation of a gas trap below (Fig. 2).

In situations where a heater is incorporated, the Pixie™ housing must be installed after or in parallel to the heater. Should a solar heating system be installed, the housing must be plumbed after the solar diverters and before the heated water rejoins the main pool return line.

Please note that your cell housing has been manufactured so that 40 mm PVC pipe will fit both inlet and outlet ports internally, and 50 mm couplings will fit externally. This allows the use of either 40 mm or 50 mm PVC pipes in the pool return line.

Gas trap - the cell housing must be installed to form a gas trap as shown below.

If water was to stop flowing and the chlorine generator continue running, gas pressure will build up in the housing and pipe work and cause damages. This can happen if water continues to run back into the electrode housing (e.g. from an outgoing pipe after the pump is turned off), allowing water to come in contact with the electrodes producing a build-up of gas. A gas trap allows the gas to displace water away from the sensor terminal, thus turning off the Chlorine generator power supply. In this scenario, status light 3 will flash and alarm will sound.

Fig. 2

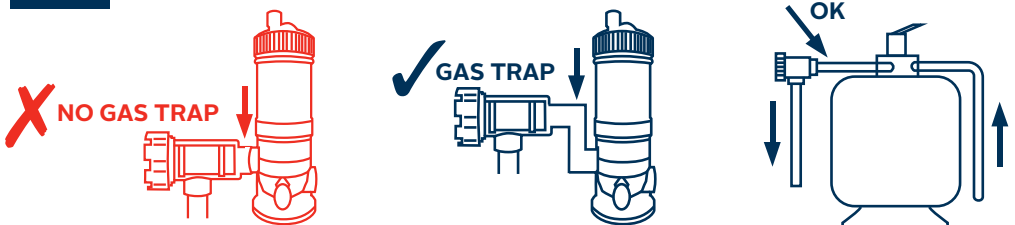

INSTALLING THE POWER SUPPLY

The Pixie™ power supply should be mounted on a wall using the fittings supplied. We recommend using the supplied mounting template provided to affix the wall plugs and mounting screws. The power supply should then slip into the keyhole slots on the rear of the unit.

It is preferable that the power supply is mounted in a location where it is protected from accidental water spray and inclement weather. It is strongly recommended that the unit is also protected and screened from the harsh sun, but in such a way that air flows freely through the structure and does not impede the natural airflow through the power supply.

You should also ensure that the power supply is not used as a shelf to store or pack objects, as this can also impede the air flow, causing overheating and/or damage to the unit that is not covered by warranty. Mount the power supply so that you can see and reach the various controls and so that the cell lead has a comfortable margin to reach the cell terminal posts. Our recommendation is that the power supply is mounted slightly higher and to one side of the filter plant to allow easy access (refer to Fig. 3).

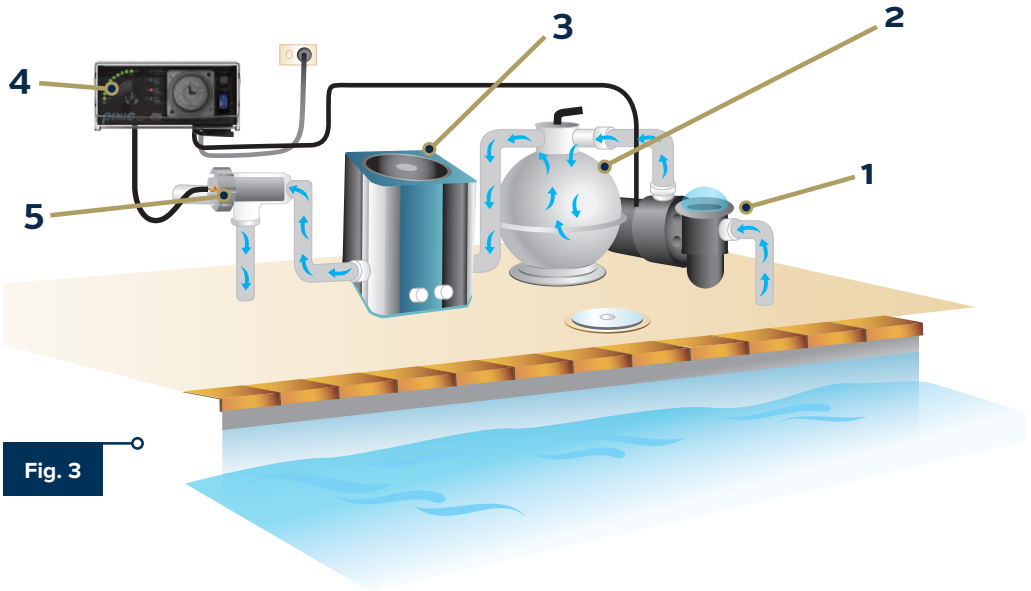

- | | |
|-----------------|--|
| 1. Pump | 4. Power supply for chlorine generator |
| 2. Filter | |
| 3. Water heater | 5. Chlorine generator cell |



RAISING THE SALINITY OF A NEW POOL

For best results the salt concentration in the pool water is required to be within an average range of approximately 4,000 to 5,500 parts per million (ppm). These figures are temperature dependant. In summertime, as water temperatures rise, salt levels may require slight reduction while in wintertime the reverse may be true to allow optimum performance of your unit.

Calculate the water volume of your pool as follows: average length x average width x average depth in metres. Multiply this answer by 4. The answer is the amount of salt in kilograms you need to add to increase the salinity of your pool from fresh water to above 4,000 ppm (the recommended minimum salinity level for this chlorine generator).

Using only refined swimming pool salt add the desired quantity to the swimming pool water. To assist in the rapid dissolving and mixing, sweep or brush the solids until they are fully dissolved. Undissolved salt may result in staining your pool finish.

As salt is heavier than water it will continue to lie at the deepest point of your pool, even though the salt granules themselves have fully dissolved. In order to ensure adequate and permanent distribution of salt throughout the pool water, we recommend additional sweeping and filter operation over a 12 – 24 hour period. Ensure that salt is totally dissolved before commencing chlorinator operation.

How to raise salinity from existing levels

To raise salinity, take the difference between the desired level and current level of salinity, divide by 1000 and multiply by known pool volume. The figure is the amount of salt in kg needed to raise to the desired level.

For example:

Current level: 3200 ppm

Desired: 5000 ppm

Pool volume: 50 m³

$5000 - 3200 = 1800$,

$1800/1000 \times 50 = 90\text{kg of salt}$

GENERAL CHLORINATOR OPERATION

Before switching on your Pixie™ saltwater chlorination system please ensure that you have added the correct amount of pool salt, it has fully dissolved and is distributed throughout the pool water. Ensure that the base pool chemistry is at the recommended levels and the pool water is clean and crystal clear (see Water Balance Section).

With the main circulation pump plugged into the pump outlet (Fig 1, item 10), switch on Pixie and set switch to bypass (Fig 1, item 9) . At this point the Pixie™ electronic display may register a water flow fault as the cell housing fills with water and an alarm (beeping) may activate. This is normal start up procedure and will cease as soon as the unit registers full and correct water flow throughout the electrodes.

With the chlorine controller knob (Fig. 1, item 5) now turned fully clockwise to the maximum position the green chlorine output indicator lights will illuminate one after the other. With the correct amount of salt added to the pool water you should achieve a 100% (ten lights) reading. In this position the Pixie™ chlorinator is producing maximum chlorine output.

Chlorine demand will differ from pool to pool due to bather load, water temperature or weather conditions and this must be taken into consideration. By testing for chlorine residuals on a regular basis you will quickly determine the chlorine state of your pool and what action you need to take to adjust it if required.

After determining your pool's chlorine needs, you can set the controller to the desired setting to achieve your chlorine requirements and/or adjust your daily running times. Normally once set, these controls do not require further adjustment except perhaps for the seasonal ones suggested earlier.

Set your chlorine controller to achieve maximum and optimum results for your pool situation. Please remember that an over chlorinated pool is not a healthy pool, so it may not be necessary for you to run your chlorinator at maximum output to maintain recommended chlorine levels.

Your Pixie™ saltwater chlorinator is fitted with a sophisticated electronic circuit board which is designed to minimise the need for manual operations and maximise cell life by constantly managing the correct operation of the power supply and electrolytic cell. In addition to the four warning lights, a warning alarm (beeper) has been installed to alert you of any problems that the electronic monitoring system has interpreted. The alarm will activate to alert you to any problems that have been detected, and once rectified the unit will resume normal operations.

Notice: When operating this device in environment with possible electromagnetic disturbances coming from inducted radio-frekvencies (RF) transmitters, the device's output (chlorine production) can rise above default setting.

CHLORINATOR RUNNING TIMES

Chlorinator running times will vary from pool to pool and are dependent upon the situation they are installed into, pool size and the overall usage of the pool in general. We recommend 2 hours break for every 4 hours of operation to prolong life of the power supply. The chlorinator should not be run for more than 10 hours continuously. It is recommended not to operate unit during the hottest part of the day and is preferable to run in early morning or late afternoon to evening.

Several factors will determine the operational time of the chlorinator to be able to produce sufficient chlorine for your pool's requirements:

- TIME:** The longer you run your filter plant and chlorinator, the more chlorine you will produce.
- RATE:** The higher the chlorine output indicator lights up; the more chlorine is being produced.
- CELL CLEANLINESS:** The cleaner the cell, the better the chlorine production rate.
- BASIC POOL CHEMISTRY:** The more correctly maintained, the less chlorine waste.
- SUNLIGHT:** UV exposure reduces chlorine levels.

POWER SUPPLY CONTROL FUNCTIONS

Your Pixie™ saltwater chlorination system has been designed for simplistic operation and control. The functions and controls (both standard and optional) and their various operations will give you a greater understanding and knowledge of the control and maintenance of both your Pixie™ unit and your pool (refer to Fig. 1 for controls).

CHLORINE CONTROLLER

(FIG. 1, ITEM 5)

The chlorine controller regulates the amount of chlorine production relevant to the position it has been set to. By adjusting the chlorine controller clockwise, you increase chlorine manufacture and by turning anti clockwise, you reduce production. Do not attempt to turn the controller beyond its stops as this could cause damage to your unit that is not covered by warranty.

CHLORINE OUTPUT INDICATOR

(FIG. 1, ITEM 6)

Your power supply is fitted with ten green indicator lights set in an arc shaped formation. During operation of your chlorinator these lights will illuminate relevant to the degree at which the chlorine controls have been adjusted. Working in conjunction with the chlorine controller you can increase or decrease chlorine output to suit your pool's requirements. As you increase the output (by turning the control knob clockwise) the corresponding lights will illuminate progressively to 100% (ten lights).

You have full control of chlorine production by adjusting the chlorine controller and illuminating the number of lights to satisfy your chlorine demand. Each light represents 10% of capable chlorine production up to its maximum output of 100% (ten lights).

STATUS INDICATOR LIGHTS

(FIG. 1, ITEMS 1, 2, 3, 4)

There are four (4) status indicator lights located on the front of your chlorinator. These advise at a glance the status of the chlorinator power supply and, when illuminated they indicate and advise about the situation that the chlorinator's electronic monitoring system has detected. The lights and their functions are listed below.



When illuminated this indicates that you have exceeded recommended salt levels. As long as this is not causing your chlorinator to overload no further action or reduction of salt concentration is required at this point. No further salt should be added if this light is illuminated.



STEADY – When illuminated in a STEADY continuous light your chlorine production has been switched off by turning the chlorine controller anti clockwise and your chlorinator power supply is now in a standby mode. Turn the chlorine controller clockwise to resume normal operation.

FLASHING – If the light is illuminated and FLASHING the monitoring system has detected low salt levels and this will need to be adjusted for the chlorinator to operate at maximum capacity. This light will also flash if the cell has reached a point where its output is below the normal operating output. Please refer to the section detailing the addition of salt to your pool.



STEADY – During normal operation this light will remain **STEADY**, indicating that power is on and the chlorinator is operating correctly.

FLASHING – When **FLASHING** the monitoring system has detected a water flow problem and has shut down to prevent damage. It will also be accompanied by a beeping alarm alerting you of this situation. When problem is rectified normal operation will resume.

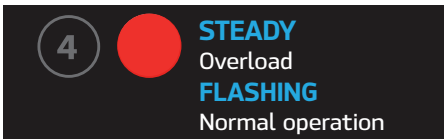

STEADY – When this light is illuminated and **STEADY** it will also be accompanied by a beeping alarm alerting you of this situation. The chlorinator has overloaded and shut down to prevent any damage. A direct short between two of the electrode plates coming into contact with each other could cause this, or a foreign object could be shorting out two or more plates. It can also be caused by a massively high concentration of salt in the pool water. Depending on the problem and rectification required, normal operations can proceed. Please note that the chlorinator power supply must be switched off and then on again to reset the electronic circuitry and resume operations.

FLASHING – When illuminated and **FLASHING** the chlorinator is operating correctly in reverse cycle mode.

SPECIAL NOTE ON WARNING INDICATOR LIGHTS:

When your chlorinator is operating in forward polarity cycle, light number 3 (Fig. 1, item 3) is on and steady while light number 4 (Fig. 1, item 4) is off.

When your chlorinator is operating in reverse polarity cycle, light number 3 remains on and steady while light number 4 will flash.

At the end of each cell operational cycle (or cell reverse), the power on/no water flow light & overload light (Fig. 1, Items 3 & 4) will **ALTERNATE** by flashing in a slow fashion for approximately thirty (30) seconds. This is the cell rinse procedure and is part of the normal operation, which occurs at each reverse cycle change of your Pixie™ reverse polarity chlorinator. On completion normal operations in the next cycle will begin.

Contrary to popular belief, during both normal and reverse cycle modes the chlorinator continues to generate chlorine, whilst at the same time the opposite polarity cell plates are being automatically cleaned.

CIRCUIT BREAKER

The circuit breaker is designed to trip out in the event of a power surge or power overload. When tripped the centre button will pop out shutting down the unit to prevent damage. To reset, depress circuit breaker until a click is heard.

ON/OFF SWITCH – ERP10H MODEL ONLY

The on/off switch is located on the front panel and has been incorporated to allow you to switch off the chlorinator function should you so desire. Please note that this switch will only shut down the chlorinator operation. It will not affect the normal filter functions.

PUMP OUTPUT SOCKET – RP10TH and RP10QTH MODELS ONLY

A 240-volt pump output power socket is supplied and located on the right-hand underside of the power supply. Your pool pump power supply lead should be plugged into this socket so that when the time clock switches at your designated times both the saltwater chlorinator and pool pump will activate in unison.

Do not attempt to operate the chlorinator power supply with the pool pump lead disconnected as this will lead to a gas build-up inside the cell housing causing it to overheat resulting in damage to your chlorinator equipment that is not covered by warranty. In extreme cases gas build-up may also cause the cell housing to rupture and explode, as it is not built to withstand this type of pressure, possibly resulting in personal injury.

The pump socket is designed to operate a single pool pump of maximum 8A only. Do not attempt to operate any equipment other than your pool pump from this socket as damage might occur to the power supply unit that is not covered under warranty.

TIME CLOCK OPERATIONS (RP10TH AND RP10QTH MODELS ONLY)

(FIG. 1, ITEM 7)

The standard timer (Grässlin model FM/1 Stuz) is designed to switch your equipment on and off at the nominated times.

Your timer has a standard clock face and hands set in the centre section, whilst the outer grey bezel shows the hours in military style (24 hour) time. To set the clock to present time, place your finger on the outer grey bezel and slowly turn it clockwise to the desired time.

SPECIAL NOTE ON TIMERS – RP10QTH Quartz Battery Backup model

If you require your Pixie™ saltwater chlorinator to be connected to a cheaper off-peak tariff, we recommend the use of an appropriate quartz time clock for that purpose.

The unit may also be hard wired in, however, in case of incorrect wiring or damage caused by modifications warranty will be void.

The Pixie™ RP10QTH (with battery backup) is available lieu of the standard model to allow time of day to be maintained when power supply is interrupted.

Start and stop times are set by pushing the black pins out for on and inward for off. For example, to turn the chlorinator on between 6 pm and 10 pm, push all the pins outwards between 18 and 22. The remainder of the pins should be pushed inwards. With the elements pushed outwards the timer will turn your equipment on when they reach the black indicators. With the elements pushed in the timer will turn your equipment off during those times.

If you switch off the unit and pump during its timer cycle by interrupting the supply of power via the power point or isolation switch, please remember to reset the time clock to present time when you reconnect unit to power (RP10TH – without quartz battery backup only).

TIMER BYPASS SWITCH (RP10TH AND RP10QTH MODELS ONLY)

(FIG. 1, ITEM 9)

On Pixie™ models fitted with a timer, a timer bypass switch will be found on the right-hand side of the time clock. This switch allows you to bypass timer functions.

Three functions are available:

TIMER:

The time clock will automatically switch your pool equipment on or off at your designated times.

OFF:

The time clock will not switch, but normal time will be maintained.

BYPASS:

The clock has bypassed all designated functions and will operate pool equipment indefinitely.

PLEASE NOTE: Return switch to 'timer' position after using the 'off' or 'by-pass' functions.



MAINTENANCE

ELECTRODE INSPECTION:

Pixie™ has a reverse polarity feature which reduces electrode cleaning. Regular inspection of the electrode is recommended.

ELECTRODE REMOVAL:

Ensure the power to the chlorine generator is switched off.

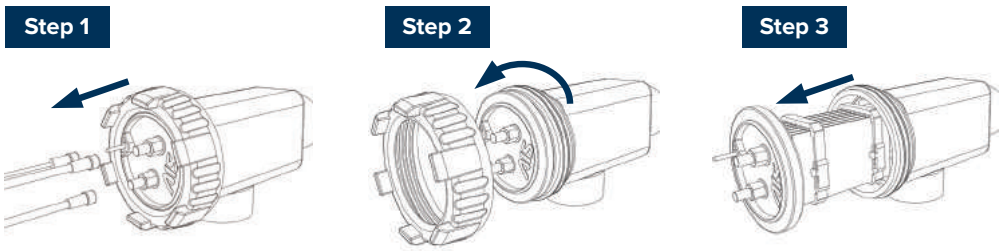

- Step 1.** Unplug the electrode lead from the electrode.
- Step 2.** Unscrew (anticlockwise) the large threaded locking nut.
- Step 3.** Remove the electrode from the housing. Look inside the electrode for signs of calcium build up (a white chalk like substance). If there is calcium build up the electrode will require cleaning. If cleaning is not required reassemble the electrode. Cleaning and reassembly are described on page 15.

ELECTRODE CLEANING:

Mix up a solution of 1-part hydrochloric acid to 8 parts water. Submerge the electrode in this solution. Do not submerge brass terminals.

CAUTION:

- When working with acid the use of eye protection, respirator, and rubber gloves are strongly recommended.
- Always refer to MSDS when dealing with hazardous chemicals.
- When mixing, add acid to water, but NEVER water to acid.

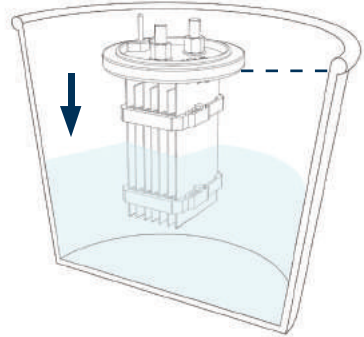

There will be a reaction as the calcium is dissolved. When the reaction ceases (about 10 minutes) rinse the electrode in clean water, wipe the brass terminals dry and check that all calcium has been dissolved. If not, repeat the process with a new solution.

ELECTRODE REASSEMBLY:

Ensure the silicon seal is still in place on the inside circumference of the electrode cap. Insert the electrode back into the housing and screw on (clockwise) the locking nut. Plug the electrode lead back on to the electrode terminals and turn on the power to the chlorine generator.

POWER SUPPLY REPAIR/MAINTENANCE:

Do not open, no user serviceable parts inside.

The power supply module and cords attached are to be serviced and/or repaired/replaced only by qualified electrician or the manufacturer.

If the supply cord is damaged, it shall only be replaced by the manufacturer or its service agent or similarly qualified person in order to avoid a hazard.

Salinity 4,000 – 5,500 ppm
TA (Total Alkalinity) 80 – 200 ppm
Chlorine 2.0 – 4.0 ppm
Cyanuric acid 30 – 50 ppm
pH 7.2 – 7.8
Phosphate 0-500ppb

TROUBLESHOOTING GUIDE

PROBLEM	REASON	SOLUTION
There are no lights on the chlorine generator and the pump is not running	<ol style="list-style-type: none"> 1. There is no mains power 2. The time clock is in a designated off period, or switch moved to OFF position. 	<ol style="list-style-type: none"> 1. Unplug the chlorine generator from the power and test power outlet with another known working appliance 2. Switch to BYPASS to circumvent TIMER or OFF functions.
Status Light (3) is on and the pump is running, but no other lights are on	The chlorine generator production is turned off	Adjust control knob clockwise to increase production.
The chlorine generator is not generating enough chlorine	<ol style="list-style-type: none"> 1. Chlorine production is reduced on the chlorine generator. 2. Chlorine generator is not operating long enough 3. Calcified electrode 4. Water chemistry is incorrect 	<ol style="list-style-type: none"> 1. Adjust control knob clockwise to increase production. 2. Increase the operation running time 3. Clean the electrode (see maintenance) 4. Correct water chemistry
Status Light (3) is flashing and the generator is beeping	<ol style="list-style-type: none"> 1. The pump is not running, filtration blocked, or air locked 2. Electrode lead not properly plugged in 	<ol style="list-style-type: none"> 1. A large air bubble in the electrode housing will cause this alarm. Clean out the skimmer box. Check & clear any blockage. Re-prime the pump. 2. Check the electrode lead plug is properly plugged onto the electrode

TROUBLESHOOTING GUIDE

PROBLEM	REASON	SOLUTION
The high salinity light is on or flashing	<ol style="list-style-type: none"> 1. Pool salinity is too high 2. Chlorine generator is faulty 	<ol style="list-style-type: none"> 1. Have the salinity level tested by pool professional and decrease to 5,500 if necessary 2. Contact dealer or AIS Water.
The low salinity light is on or flashing	<ol style="list-style-type: none"> 1. Water salinity is too low 2. Electrode is calcified 3. Faulty electrode 	<ol style="list-style-type: none"> 1. Have the salinity level tested by pool professional and increase it to 4000 ppm if necessary 2. Clean electrode (see maintenance) 3. Have the electrode tested and replace if necessary
There is a white powdery material on the pool bottom.	Excessive water hardness.	Test the water chemistry and adjust accordingly.
Circuit breaker is tripping.	<ol style="list-style-type: none"> 1. Mains power surge. 2. Fault with shorted electrodes. 3. Fault with power supply 	<ol style="list-style-type: none"> 1. Set machine to off and push circuit breaker. 2. a) Visually inspect electrode and check for foreign or conductive surfaces. If found, remove and clean cell. b) Check electrode plates are not contacting/touching each other. If yes, replace cell. 3. Contact dealer or AIS Water.

TECHNICAL SPECIFICATIONS

Chlorine output	10 g/hr (grams of chlorine gas equivalent per hour)
Input voltage (V)	220-240v, 50 hz
Input current (A)	0.4 amps
Output voltage (V)	8 v
Output current (A)	6.5 amps
Unit cooling	Convection, via external heatsink
No flow protection	Automatic water flow sensing
Water flow rate	150 – 450 lt/minute. 480 kpa max. pressure
Warranty	4 years (48 months) for residential applications 1 year (12 months) for commercial applications

Note: 1 gram of chlorine gas equivalent is approximately equal to 10 ml of 10% liquid sodium hypochlorite (liquid pool chlorine).



WARRANTY

Your Pixie™ chlorine generator is covered by a forty-eight (48) month in-factory repair warranty, on all parts and labour, from the date of purchase. This warranty applies to the original purchaser and is not transferable.

All chlorine generators are fully tested prior to being packed. If within 48 months of purchase a problem occurs due to faulty workmanship or components, AIS Water will (at their discretion) repair or replace the chlorine generator.

The manufacturer will not be liable for any consequential loss or damage caused by operation outside the prescribed limits as outlined in the instruction manual, incorrect installation, connection to an incorrect mains power supply, changes to internal wiring, misuse, abuse, negligence, accidental damage, normal wear and tear, or damage caused by water entry.

Note: This warranty is strictly in-factory repair. In the case of failure, the complete unit must be returned to the manufacturer or their designated agent. All forward and return costs are the responsibility of the owner.

CONTACT DETAILS

In the unlikely event of a problem with your chlorine generator, please contact:

Warranty Hotline: 1800 676 076

Online warranty aiswater.com.au and go to: Support – Warranty Requests.

For assistance outside of the warranty period: call +61 7 3396 5222

Your local dealer:



For international warranty claims: Please contact your local dealer.



AIS Contacts

Head Office +61 7 3396 5222

51 Millennium Place, Tingalpa, Queensland 4173 Australia

Email: info@aiswater.com.au

Facsimile

+61 7 3393 3441

WARRANTY HOTLINE 1800 676 076 (Australia wide)

AUTOCHLOR EUROCENTER

Trygon Pacific International

Phone: +420 475 221 695

E-mail: info@autochlor.eu

www.autochlor.eu

AIS

WATER

Enhancing life

aiswater.com.au

Scan any AIS Water logo to learn "Why choose AIS?"

